

MAQUINA	DESCRIPCION
QCGE1835	CLAVADORA CORGRAP ELECT. E18/35

DESDE FECHA	28/11/14
HASTA FECHA	31/12/2099

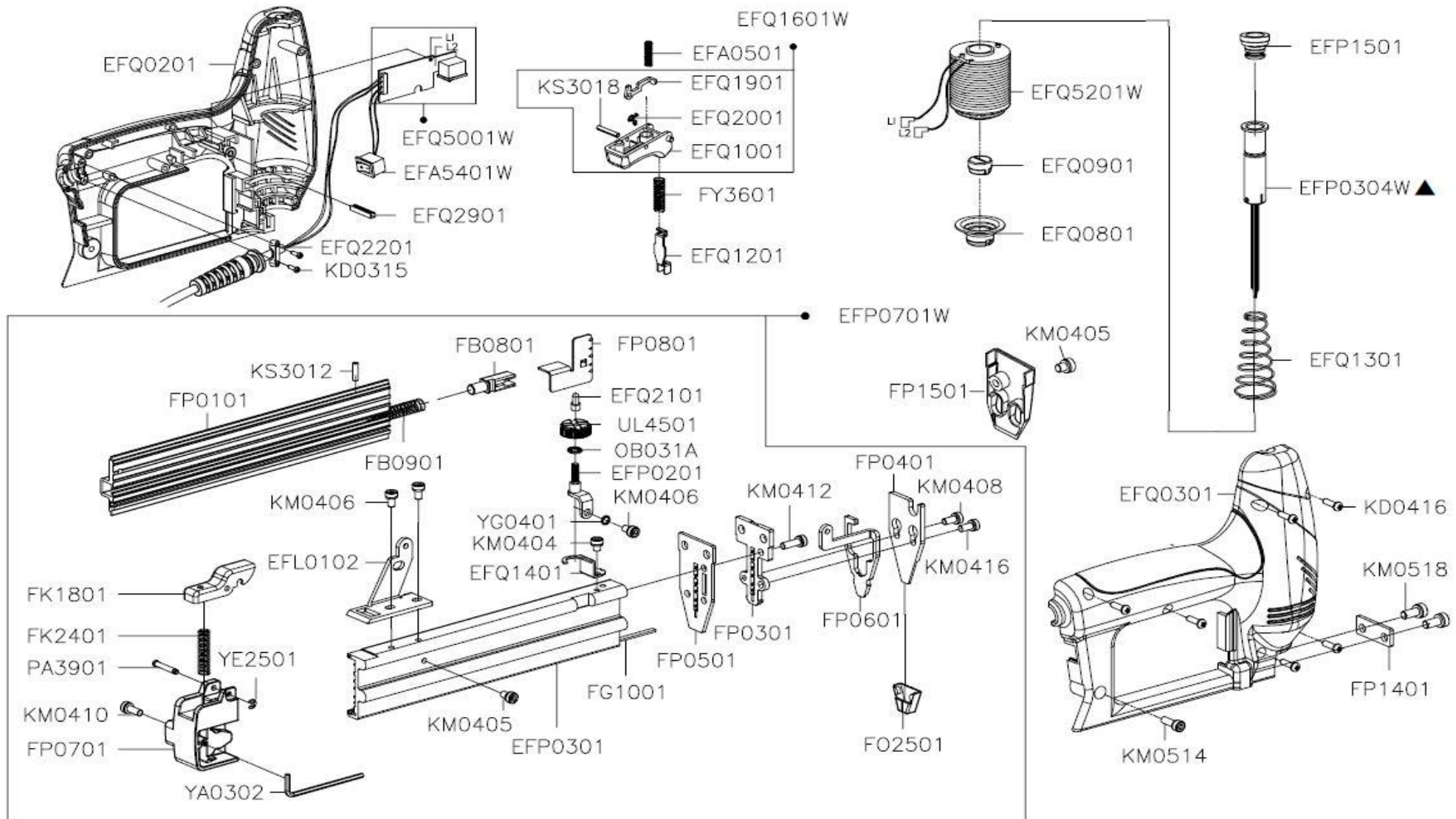



MAQUINA	DESCRIPCION	DESDE FECHA	28/11/2014
QCGE1835	CLAVADORA CORGRAP ELECT. E18/35	HASTA FECHA	31/12/2099

RECAMBIO	DESCRIPCION	CANTIDAD	POSICION
RAPEFA0501 (EFA0501)	MUELLE EFA0501	1	EFA0501
RAPEFA5401W (EFA5401W)	INTERRUPTOR EFA5401W	1	EFA5401W
RAPEFL0102 (EFL0102)	SOPORTE EFL0102	1	EFL0102
RAPEFP0201 (EFP0201)	SOPORTE EFP0201	1	EFP0201
RAPEFP0301 (EFP0301)	CARGADOR EFP0301	1	EFP0301
RAPEFP0304W (EFP0304W)	CUCHILLA EFP0304W	1	EFP0304W
RAPEFP0701W (EFP0701W)	CARGADOR EFP0701W	1	EFP0701W
RAPEFP1501 (EFP1501)	TOPE EFP1501	1	EFP1501
RAPEFQ0201 (EFQ0201)	CUERPO EFQ0201	1	EFQ0201
RAPEFQ0301 (EFQ0301)	CUERPO EFQ0301	1	EFQ0301
RAPEFQ0801 (EFQ0801)	CASQUILLO EFQ0801	1	EFQ0801
RAPEFQ0901 (EFQ0901)	TOPE EFQ0901	1	EFQ0901
RAPEFQ1001 (EFQ1001)	GATILLO EFQ1001	1	EFQ1001
RAPEFQ1201 (EFQ1201)	LEVA EFQ1201	1	EFQ1201
RAPEFQ1301 (EFQ1301)	MUELLE EFQ1301	1	EFQ1301
RAPEFQ1401 (EFQ1401)	SOPORTE EFQ1401	1	EFQ1401
RAPEFQ1601W (EFQ1601W)	GATILLO EFQ1601W	1	EFQ1601W
RAPEFQ1901 (EFQ1901)	LEVA EFQ1901	1	EFQ1901
RAPEFQ2001 (EFQ2001)	CER-CLIP EFQ2001	1	EFQ2001
RAPEFQ2101 (EFQ2101)	EJE EFQ2101	1	EFQ2101
RAPEFQ2201 (EFQ2201)	ARANDELA EFQ2201	1	EFQ2201
RAPEFQ2901 (EFQ2901)	PROTECTOR EFQ2901	1	EFQ2901
RAPEFQ5001W (EFQ5001W)	CIRCUITO ELÉCTRICO EFQ5001W	1	EFQ5001W
RAPEFQ5201W (EFQ5201W)	BOBINA ELÉCTRICA EFQ5201W	1	EFQ5201W
RAPFB0801 (FB0801)	EMPUJADOR FB0801	1	FB0801
RAPFB0901 (FB0901)	MUELLE FB0901	1	FB0901
RAPFG1001 (FG1001)	GUÍA FG1001	1	FG1001



MAQUINA	DESCRIPCION	DESDE FECHA	28/11/2014
QCGE1835	CLAVADORA CORGRAP ELECT. E18/35	HASTA FECHA	31/12/2099

RECAMBIO	DESCRIPCION	CANTIDAD	POSICION
RAPFK1801 (FK1801)	CIERRE FK1801	1	FK1801
RAPFK2401 (FK2401)	MUELLE FK2401	1	FK2401
RAPFO2501 (FO2501)	PROTECTOR FO2501	1	FO2501
RAPFP0101 (FP0101)	CARGADOR FP0101	1	FP0101
RAPFP0301 (FP0301)	GUÍA FP0301	1	FP0301
RAPFP0401 (FP0401)	GUÍA FP0401	1	FP0401
RAPFP0501 (FP0501)	GUÍA FP0501	1	FP0501
RAPFP0601 (FP0601)	SEGURO FP0601	1	FP0601
RAPFP0701 (FP0701)	CUBIERTA FP0701	1	FP0701
RAPFP0801 (FP0801)	EMPUJADOR FP0801	1	FP0801
RAPFP1401 (FP1401)	PLATINA FP1401	1	FP1401
RAPFP1501 (FP1501)	PROTECTOR FP1501	1	FP1501
RAPFY3601 (FY3601)	MUELLE FY3601	1	FY3601
RAPKD0315 (KD0315)	TORNILLO KD0315	2	KD0315
RAPKD0416 (KD0416)	TORNILLO KD0416	6	KD0416
RAPKM0404 (KM0404)	TORNILLO KM0404	1	KM0404
RAPKM0405 (KM0405)	TORNILLO KM0405	2	KM0405
RAPKM0406 (KM0406)	TORNILLO KM0406	3	KM0406
RAPKM0408 (KM0408)	TORNILLO KM0408	1	KM0408
RAPKM0410 (KM0410)	TORNILLO KM0410	1	KM0410
RAPKM0412 (KM0412)	TORNILLO KM0412	1	KM0412
RAPKM0416 (KM0416)	TORNILLO KM0416	1	KM0416
RAPKM0514 (KM0514)	TORNILLO KM0514	1	KM0514
RAPKM0518 (KM0518)	TORNILLO KM0518	2	KM0518
RAPKS3012 (KS3012)	PASADOR KS3012	1	KS3012
RAPKS3018 (KS3018)	PASADOR KS3018	1	KS3018
RAPOB031A (OB031A)	ANILLO TÓRICO OB031A	1	OB031A



<b>MAQUINA</b>	<b>DESCRIPCION</b>	<b>DESDE FECHA</b>	28/11/2014
QCGE1835	CLAVADORA CORGRAP ELECT. E18/35	<b>HASTA FECHA</b>	31/12/2099

<b>RECAMBIO</b>	<b>DESCRIPCION</b>	<b>CANTIDAD</b>	<b>POSICION</b>
RAPPA3901 (PA3901)	PASADOR PA3901	1	<b>PA3901</b>
RAPUL4501 (UL4501)	GRADUADOR UL4501	1	<b>UL4501</b>
RAPYA0302 (YA0302)	LLAVE ALLEN YA0302	1	<b>YA0302</b>
RAPYE2501 (YE2501)	CER-CLIP YE2501	1	<b>YE2501</b>
RAPYG0401 (YG0401)	ARANDELA YG0401	1	<b>YG0401</b>